



INSTRUCTIONS FOR METAL BENDER BENCH & FLOOR MOUNTING

MODEL NO'S: **PBB04.V2 & PBF04.V2**

Thank you for purchasing a Sealey product. Manufactured to a high standard, this product will, if used according to these instructions, and properly maintained, give you years of trouble free performance.

IMPORTANT: PLEASE READ THESE INSTRUCTIONS CAREFULLY. NOTE THE SAFE OPERATIONAL REQUIREMENTS, WARNINGS & CAUTIONS. USE THE PRODUCT CORRECTLY AND WITH CARE FOR THE PURPOSE FOR WHICH IT IS INTENDED. FAILURE TO DO SO MAY CAUSE DAMAGE AND/OR PERSONAL INJURY AND WILL INVALIDATE THE WARRANTY. KEEP THESE INSTRUCTIONS SAFE FOR FUTURE USE.



Refer to instruction manual



Wear eye protection



Wear protective gloves

1. SAFETY

- ✓ Ensure that the metal bender is in sound condition and good working order. Take action for immediate repair or replacement of damaged parts. *Use recommended parts only. The use of improper parts may be dangerous and will invalidate the warranty.*
- ✓ Locate the bender in a suitable, well lit work area.
- ✓ Keep work area clean and tidy and free from unrelated materials.
- ✓ Mount onto a strong, stable work surface or onto level and solid ground (preferably concrete) as appropriate.
- ✓ Ensure all non-essential persons keep a safe distance whilst the bender is in use.
- ✓ Check that all bending dies, pins, stops and attachments are correctly and securely mounted before commencing a bend.
- ✓ Wear safety goggles and gloves when bending parts.
- ✓ Always allow enough material to extend beyond the stop block and forming dies when making bends to ensure that the material does not come free allowing the handle to release suddenly.
- ✗ **DO NOT** bend any material other than hot rolled mild steel.
- ✗ **DO NOT** operate the metal bender if damaged.
- ✗ **DO NOT** allow untrained persons to operate the bender.
- ✗ **DO NOT** use the metal bender for purposes other than that for which it is intended.
- ✗ **DO NOT** try to bend round stock using the sharp angle attachment.
- ✗ **DO NOT** modify the bender in any way or use a handle extension other than the one provided.
- ✗ **DO NOT** try to bend material larger than the maximum sizes stipulated below.

2. INTRODUCTION

Manually operated bench and floor mounted metal bender. Capable of producing radiused and angles bends in strips up to 50 mm wide and radiused bends in round/square stock up to 16 mm dia/side. Supplied with seven dies, 1" to 3" .

3. SPECIFICATION

Model no's:..... PBB04.V2, PBF04.V2
 Die Diameters:1", 1-1/4", 1-1/2", 1-3/4", 2", 2-1/2", 3"
 Bending Capacity (Die):
 Flat Material: up to 5/16" x 2"
 Square or Round Material: up to 5/8"
 Bending capacity (Angle Attachment):
 3/16" Flat Mild Steel: up to 2" wide
 1/4" Flat Mild Steel: up to 1-1/4" wide

4. ASSEMBLY

- WARNING!** Ensure that you have read and understood Section 1 Safety Instructions before operating the bender.
- WARNING!** To avoid serious injury do not operate the bender unless it is securely mounted to the floor or workbench.

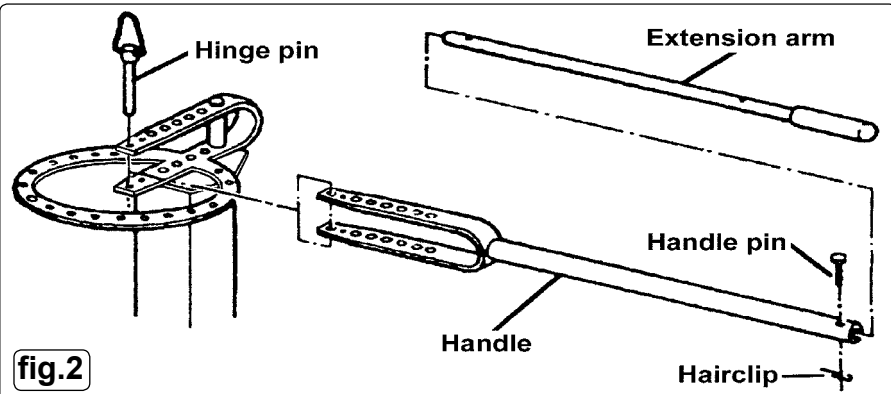
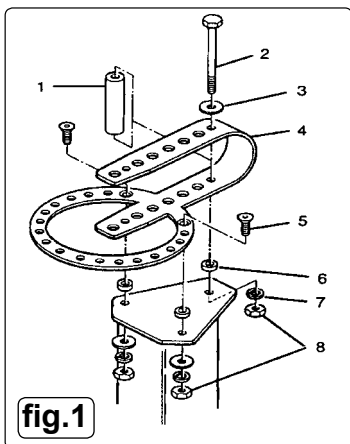

- 4.1. **Attach the ring/loop assembly to the floor stand or bench stand as indicated in fig.1.**
- 4.1.1. Attach the loop end first by placing the long spacer (1) into the loop. Place a flat washer (3) over the bolt (2) and insert the bolt through the loop and long spacer. Insert the protruding bolt into the mounting plate at the top of the stand ensuring that there is a short spacer (6) sandwiched between the loop and the mounting plate. Secure with a lock washer (7) and a nut (8).
- 4.1.2. Attach the ring end to the stand in the two places indicated using the two 3/8" bolts with countersunk heads (5). Ensure that there is a short spacer (6) inserted between the ring and the mounting plate through which each bolt passes. Place a flat washer and a lock washer over each bolt and secure with a lock nut.
- 4.2. **Attach the handle to the ring/loop as indicated in fig.2.**
- 4.2.1. Insert the loop end of the handle inside the loop of the ring/loop assembly and secure it with one of the two longer hinge pins. The hole selected on the handle loop will depend on the type of bend to be done. (See section 4)
- 4.3. **Extend the handle to its full length. (See fig.2)**
- 4.3.1. Remove the R clip from the handle pin, then remove the pin from the handle. Pull the extension arm out of the handle tube and align the hole at the end of the extension with the hole in the handle tube. Reinsert the pin and retain it by reinstalling the hairclip.
- 4.4. **Fix the assembled unit to the floor or bench as appropriate.**
- 4.4.1. Place the bender in the position where you intend to use it and rotate the handle fully in both directions to ensure that there will be no obstructions during bending. The bender must be attached to a bench or floor using fixings which are strong enough to resist the turning force exerted on them. Similarly the structure of the bench or floor surface must also be sound and strong enough to resist the turning force exerted through the fixings.

5. OPERATION

- 5.1. The bender can produce two basic types of bend.
- Smooth radiused bends using a combination of the circular dies provided.
 - Sharp bends using the sharp angle attachment.
- 5.2. **Making a test piece**
- When producing parts from dimensioned drawings it is advisable to make a test part first from scrap material of the same thickness to be used in the final part. A certain amount of trial and error may be necessary in setting up the bender to achieve an accurate part. To achieve a particular bend angle you will need to make a trial bend first and then measure it. Using the fixed or adjustable stop. Further adjustments may be necessary but once you know the amount of rotation necessary to achieve a particular angle this can be repeated by using the fixed or adjustable stops provided. (See figs.3&11)
- 5.3. **Multiple bends**
- When doing more than one bend, similar trial and error may be necessary to establish the correct relationship between bends. Mark the bend positions on the trial workpiece. Make the bends and then measure the distance between them. Make any necessary adjustments to the measurement to achieve the desired result.
- 5.4. **Bend sequence**
- Where a number of bends are to be made in the same piece of metal attention should be paid to the order in which the bends are made to achieve the finished part. You may need to re-orientate the workpiece in the bender by reversing it or inverting its position. If necessary the bender can be disassembled to remove or reposition a complex bend configuration.
- 5.5. **Clamping the workpiece**
- Generally the workpiece is automatically clamped in place by the action of the bender. In certain instances some slippage may occur e.g. when forming material around a large die. This can be eliminated by clamping the end of the material with locking pliers which then act against the stop block to prevent the material moving. (See fig.4)
- 5.6. **Making radiused bends**
- Do not try to bend material more than 1/4" thick around the centre pin. The 1" die must be used.

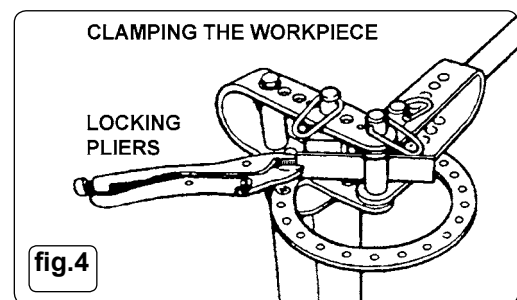
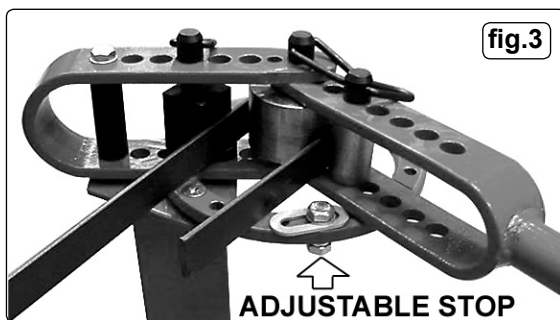

- 5.8. **Use of the 'stop block'**
- The 'stop block' prevents the material from rotating in the bender while a forming die mounted in the handle bends the material either round the centre pin or around another die that has been installed on the centre pin.
- 5.9. **Orientation of the 'stop block'**
- The 'stop block' can be placed in several orientations allowing additional flexibility in the positioning of the workpiece in relation to the forming dies. Its relationship to the workpiece is altered by rotating it on the hinge pin or by turning it upside down on the pin and rotating it. However, only the four orientations shown in fig.5 should be used for bending. No matter which face is against the workpiece, the pin through the block should always be positioned to the right of the block centre otherwise the block may turn and the material will slip in the bender.

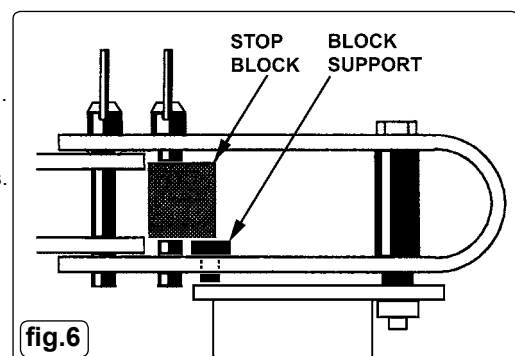

- 5.10. **Position of the block support**
- The block support is used to position the stop block vertically in the ring assembly loop as shown in fig.6. Install the support in the appropriate loop hole where it will support the block but not interfere with the insertion of the hinge pin all the way through the the hole in the block and into the hole in the lower part of the loop.

5.11 **Installing the dies**

Install in the centre of the bender the chosen die around which you are going to form the metal. Use a long hinge pin to retain both the die and the handle as shown in fig.7. Install the die which will do the forming into the handle loop and retain it using the short hinge pin. The space between the two dies should be as small as possible whilst allowing the metal to pass through.

5.12 **Installing the stop block and block support**

Rotate the handle anticlockwise to the approximate starting position as shown in fig.7. Insert the metal to be formed in between the dies. Now install the stop block and block support at one of the five large holes in the ring assembly's loop. You will have to determine by trial and error which hole to use depending on the thickness of the material being bent, the size of the centre pin die, and the orientation of the stop block. The block should be as close to the centre pin/die as the material will allow. Retain the stop block with a long hinge pin.

WARNING! When making a bend or partial bend close to the end of a piece of material the bending force you are exerting on the handle may suddenly be released as the bending die in the handle rolls off the end of the material. Watch the progress of the die as it moves towards the end of the material and be prepared to release the pressure on the handle.

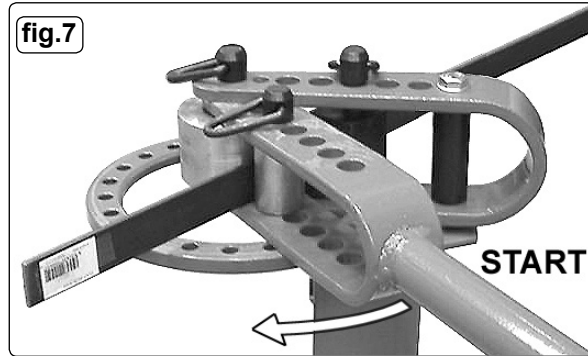
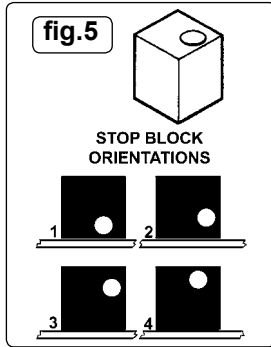

5.13 **Making a bend** (Before making a bend check that the bender is still firmly attached to the bench or floor. The floor should be clean and dry and free from loose material. Wear non slip shoes and check that the area is clear of personnel and will remain clear whilst you are executing the bend.)

If required, clamp the workpiece as shown in fig.4. Exert just enough pressure on the handle to hold the material steady in the bender and check that the material is level. Make the bend with steady and even pressure until you reach the desired finishing point as indicated in fig.8. (As a rough guide to initially determine an angle when bending around a centrally mounted die there are 16.36 degrees between the holes in the ring.) Measure the angle bent and make any necessary adjustments.

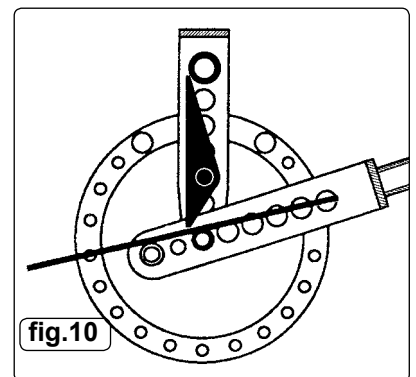
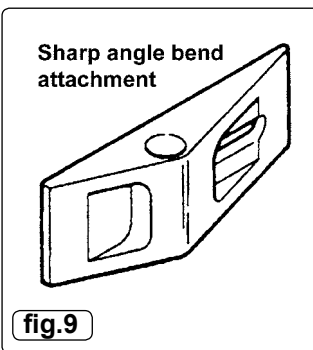
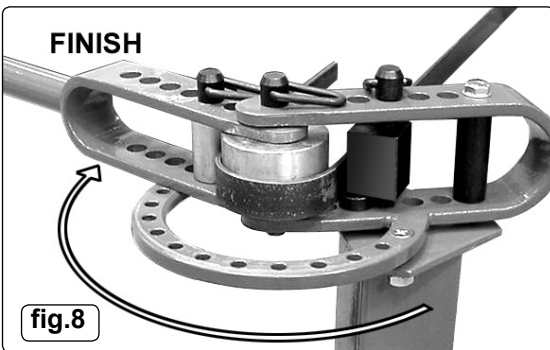

5.14 **Installing the sharp angle bend attachment**

The sharp angle bend attachment has only one correct orientation as shown in fig.10. and should be installed with the block support underneath it to raise it to the correct position vertically within the loop. Counting from the outside of the loop towards the centre of the bender place the block support in the third lower hole. Rest the sharp bend attachment on the block support and secure it by dropping a long hinge pin through the fourth upper hole and all the way through the hole in the attachment into the hole in the lower part of the loop. The longer 'tail' of the attachment should now be resting to the left of the loop spacer as shown in fig.10

5.15 **Installing the handle**

Counting from the outside of the handle loop towards the centre of the bender align the sixth hole in the handle with the centre pivot hole of the bender. Secure the handle by dropping a long hinge pin through both loops.

5.16 **Installing the handle die**

Install the smallest die in the last hole in the handle loop as shown in fig.11 using a short hinge pin.

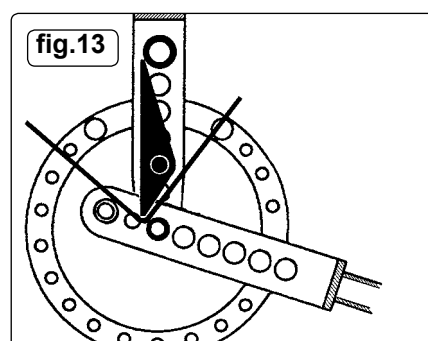
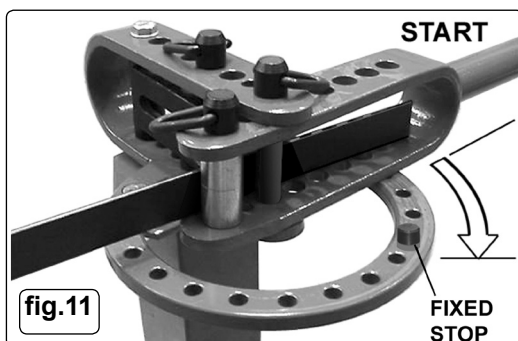

5.17 **Preparation of workpiece**

Mark the position of the bend or bends onto the material. These marks will represent the inside of each bend and therefore may be on different sides of the material depending on the shape of the item you are making. (If you are making two right angle bends on the same side of the material, make the marks 3mm further apart than the desired inside dimension after the bend.)

5.18 **Making a bend.**

(Before making a bend check that the bender is still firmly attached to the bench or floor. The floor should be clean and dry and free from loose material. Wear non slip shoes and check that the area is clear of personnel and will remain clear whilst you are executing the bend.) Slide the material into the bender so that the first marked out bend is aligned with the tip of the sharp angle attachment. (The material face that is touching the tip of the sharp angle attachment will become the inside of the bend. See fig.13 which shows the action of the bender when using the sharp angle attachment.)

Exert just enough pressure on the handle to hold the material steady in the bender and check that the material is level. Make the bend with steady and even pressure until you reach the desired finishing point as indicated in fig.12. Measure the angle and make any necessary adjustments. Once the required movement for a particular angle has been established it can be repeated by the use of the fixed stop as shown in figs.11 & 12. If the finish point of a bend falls between two holes use the adjustable stop as shown in fig.3.

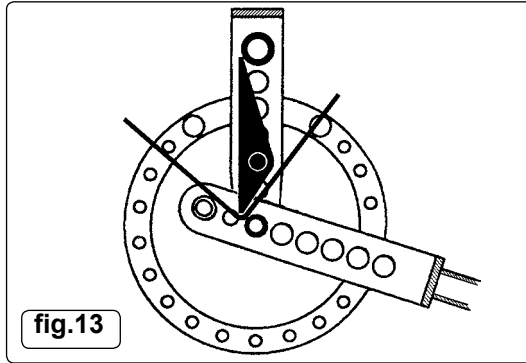
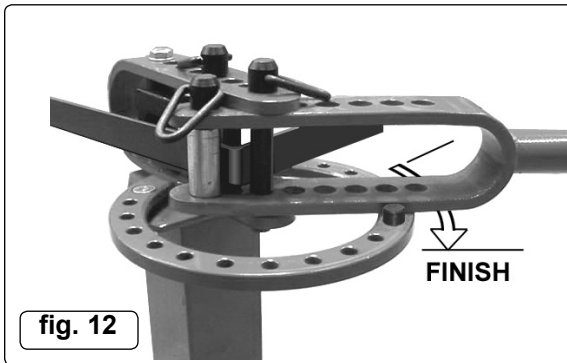

5.19 Below is illustrated a simple example of the bend sequence required to make a simple pipe clamp using both methods of bending. The first two bends are around a 1" die mounted on the centre pin with the stop block in place. The last two bends are made using the sharp angle attachment. To insert the workpiece in C & D it will be necessary to temporarily remove the centre pin. Dis-assemble the handle to remove the finished piece.

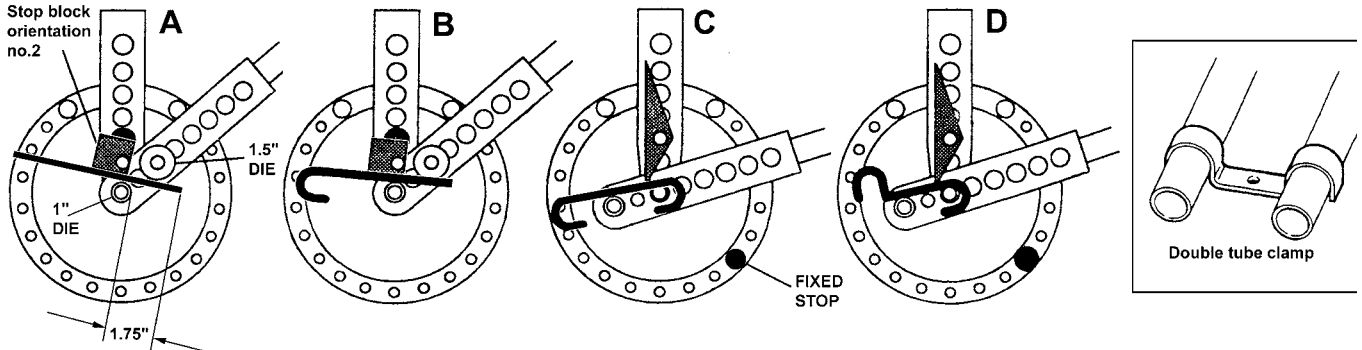

ENVIRONMENT PROTECTION

Recycle unwanted materials instead of disposing of them as waste. All tools, accessories and packaging should be sorted, taken to a recycling centre and disposed of in a manner which is compatible with the environment. When the product becomes completely unserviceable and requires disposal, drain any fluids (if applicable) into approved containers and dispose of the product and fluids according to local regulations.

Note: It is our policy to continually improve products and as such we reserve the right to alter data, specifications and component parts without prior notice.

Important: No Liability is accepted for incorrect use of this product.

Warranty: Guarantee is 12 months from purchase date, proof of which is required for any claim.

Sealey Group, Kempson Way, Suffolk Business Park, Bury St Edmunds, Suffolk. IP32 7AR

01284 757500

01284 703534

sales@sealey.co.uk

www.sealey.co.uk