



1500KG AIR/HYDRAULIC COIL SPRING COMPRESSING STATION

MODEL NO: RE232.V3

Thank you for purchasing a Sealey product. Manufactured to a high standard, this product will, if used according to these instructions, and properly maintained, give you years of trouble free performance.

IMPORTANT: PLEASE READ THESE INSTRUCTIONS CAREFULLY. NOTE THE SAFE OPERATIONAL REQUIREMENTS, WARNINGS & CAUTIONS. USE THE PRODUCT CORRECTLY AND WITH CARE FOR THE PURPOSE FOR WHICH IT IS INTENDED. FAILURE TO DO SO MAY CAUSE DAMAGE AND/OR PERSONAL INJURY AND WILL INVALIDATE THE WARRANTY. KEEP THESE INSTRUCTIONS SAFE FOR FUTURE USE.



Refer to instructions



Wear eye protection



Wear protective gloves



Beware coil binding



No reaching in

1. SAFETY

1.1. GENERAL SAFETY

IMPORTANT! Ensure Health & Safety, local authority regulations, and general safe workshop practices are adhered to when using this equipment.

IMPORTANT! Wear approved safety hand and eye protection (standard spectacles are not adequate).

IMPORTANT! TRAPPING DANGER – Keep hands and fingers away from the spring and compressing jaws in use.

- ✓ Familiarise yourself with the applications, limitations and potential hazards of the spring compressor.

▲ **CAUTION! DO NOT** use the spring compressor for a task it was not designed to perform.

▲ **CAUTION! DO NOT** allow untrained persons to use the spring compressor.

- ✓ Keep the work area clean, uncluttered and ensure there is adequate lighting.

1.2. PRE-OPERATIONAL SAFETY

- ✓ Apply a little transmission oil to the front and rear faces of the main upright to assist the smooth action of the compressor.

✗ **DO NOT** operate compressor if damage is seen, parts are damaged or missing as this may cause failure and/or personal injury.

- ✓ Before commencing compression, carry out a visual inspection of compressor to ensure pins are securely positioned and that there are no sign of wear or fatigue – if found, **DO NOT** use and refer to your local Sealey stockist for advice and replacement parts.

- ✓ Ensure jaw locating pins are properly positioned and safety clips are attached correctly.

- ✓ Before commencing compression of spring, ensure coils of the spring are seated securely in the yokes of the compressor and cannot slide out during compression.

- ✓ If the restraint system is in use, ensure that the safety guard locks in place. Use the chain to secure the spring safely.

1.3. OPERATIONAL SAFETY

▲ **CAUTION!** Stop compressing the spring before the coils touch / bind.

▲ **CAUTION!** Before attempting to remove top strut-nut, always use a tool or similar to test if the compression has been relieved, **DO NOT** use your hands / fingers.

- ✓ When applying compression to the spring, always stand to one side of the compressor.

- ✓ We recommend the use of purpose made strut tools to remove the top strut-nut.

- ✓ Once compressed, and the strut removed, we recommend releasing the tension on the spring. **DO NOT** leave the spring under compression in the machine unattended and **DO NOT** leave in compression for prolonged periods, i.e. overnight.

- ✓ Before releasing the compression ensure that the top strut-nut is securely tightened to the manufacturer's tolerance.

- ✓ Release the compression slowly keeping your hands and fingers away from the spring assembly.

- ✓ Be sure that the tension on the spring is fully controlled by the strut assembly before removing it from the yokes of the compressor.

1.4. POST OPERATIONAL SAFETY

- ✓ When not in use, clean and store the spring compressor in a safe, dry, childproof location.

- ✓ Maintain the spring compressor in good condition. Replace with genuine Sealey parts only.

- ✓ Unauthorised parts may be dangerous and will invalidate the warranty.

2. INTRODUCTION

1500kg Air actuated hydraulic unit with alternative foot operation. Quicker and easier than using ratchet driven spring compressor. Plastic coated yokes reduce the risk of spring slippage or damage and are suitable for springs from Ø80mm to Ø175mm.

3. SPECIFICATION

Model No:	RE232.V3
Maximum Load:	1500kg
Upper Yoke Positions:	7
Lower Yoke Travel:340mm
Spring Diameter:	80-175mm
Actuation:	Air or Foot Pedal
Maximum Air Pressure:120psi (8.3bar)
Coil Spring Compressor Restraint System: (not supplied). . . .	RE23RS

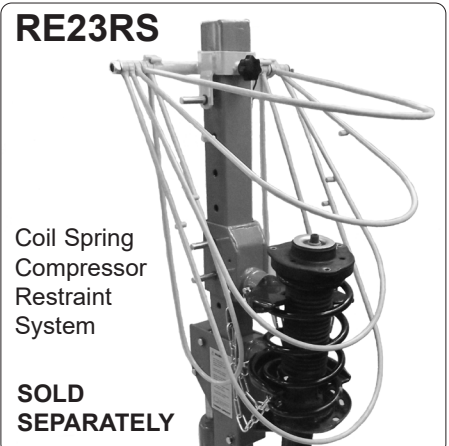

4. ASSEMBLY

REFER TO ATTACHED PARTS DIAGRAM

- 4.1. Attach the brackets to the base using the fixings shown on the parts diagram.
- 4.2. Attach the pedal to the pump and secure.
- 4.3. Attach the chains, one to each side of the upper strut support, refer to (fig.1).
IMPORTANT: secure the machine to the floor. The brackets are drilled to accept bolts which should be secured to suitable fixings.
- 4.5 **MOUNTING THE YOKES (See fig.1)**
 - 4.5.1 Push the required yoke onto the yoke mounting spigot.
 - 4.5.2 Secure with the yoke retaining pin and insert the 'R' clip.
 - 4.5.3 Repeat to secure the lower yoke with its pin and 'R' clip.
 - 4.5.4 Make sure that the correct size yokes are installed with the bottom yoke facing up and top yoke facing down.

5. AIR SUPPLY

- WARNING! Ensure air supply is clean and does not exceed 120psi (8.3bar). Too high an air pressure and unclean air will shorten the life of the unit due to excessive wear, and may be dangerous causing possible damage and/or personal injury.**
- 5.1. Connect the air control valve to the air supply hose.
 - 5.2. For recommended connection, see diagram.
 - 5.3. Drain the air supply tank daily and clean the air inlet filter screen weekly.
 - 5.4. Line pressure should be increased to compensate for long air hoses (over 8mtr).
 - 5.5. Keep hoses away from heat, oil and sharp edges. Check for wear and make sure that all connection are secure.

6. OPERATION

6.1. COMPRESSING A STRUT SPRING

- 6.1.1. **NOTE:** Before removing the strut from the vehicle it is recommended that the upper strut locking plate nut is loosened a quarter turn. **DO NOT** loosen more than a quarter turn.
- 6.1.2. With the strut and spring removed from the vehicle, select the most suitably sized yoke according to the size of the spring and fit it onto the compressor using the locking pin to hold it in position (fig.1).
- 6.1.3. Move the upper support to the required height in order to accommodate the spring. Do this by releasing the two upper yoke locking pins (fig.1), moving the support and replacing the pins, ensuring that the 'R' clips are inserted.
- 6.1.4. Place the spring between the yokes, rotate into place, then wrap the safety chains around the spring.
- 6.1.5. Position one chain around a coil protruding above the top yoke (fig.2A) and the other chain below the bottom yoke (fig.2B). Check that neither chain could be trapped between the coils. Ensure that the chains are as tight as possible.
- 6.1.6. Apply light hydraulic pressure with the pump pedal and check that the spring is seated correctly.
 - ▲ **DANGER!** Stop compressing the spring before the coil windings touch/bind.
 - WARNING!** If the spring/strut is not located correctly in the yokes, it is possible that the strut top retaining cap could be subject to sideways forces. Watch closely as the spring reaches it's final phase of compression and ensure the top cap assembly rotates freely before attempting to remove it.
- 6.1.7. If the spring is seated correctly, use either the air control valve or pedal to continue compressing the spring, standing to the side of the machine.
- 6.1.8. Compress the spring gradually, making sure that the spring stays seated in the yokes.
- 6.1.9. When compressing conical springs; the centre line of the spring should remain parallel to the compressor body.
 - WARNING!** Check that the nut is free by using a metal or wooden item.
 - × **DO NOT** check with fingers or hands.
- 6.2. It is recommended that a purpose-made strut nut socket is used to remove the nut.
 - 6.2.1. Support the shock absorber to prevent it falling clear when released.
 - × **DO NOT** leave the spring compressed, release the pressure on the spring if it is to be left for any time.
 - 6.2.2. Decompress the spring by pressing the release valve pedal (next to the pump pedal) gradually.

6.3. FITTING A STRUT SPRING

- 6.3.1. Offer the new strut spring up to the compressor's yokes and fit it in the same position as that of the old spring.
- 6.3.2. Position the lowest coil of the spring in the lower yoke and rotate the spring, so that the coil is held as low as possible. Position the upper yoke below the top coil. Ensure that the coil is placed inside the recesses of the yokes to ensure that the coil will not break free under compression.
NOTE: There must be coils free at either end to allow them to seat on the strut plates, without the strut and compressor yokes interfering.
- 6.3.3. Position one chain around a coil protruding above the top yoke (fig.2A) and the other chain below the bottom yoke (fig.2B). Check that neither chain could be trapped between the coils. Ensure that the chains are as tight as possible.
 - ▲ **DANGER!** Stop compressing the spring before the coil windings touch or bind.
 - WARNING!** Keep hands away from spring.
- 6.3.5. Compress the spring using the correct pedal on the foot control unit, ensuring that the spring is securely held in place within the clamp recesses at all times. When the spring is compressed sufficiently, fit the strut top plate to the strut, and using a new nut, secure it in position.
- 6.3.6. Decompress the spring carefully and slowly, using the pedal on the foot control unit, ensuring the spring is located correctly into the strut top plate.

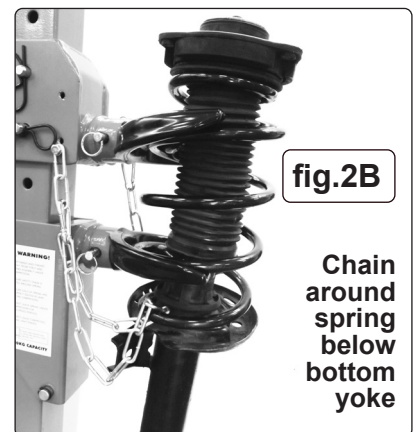
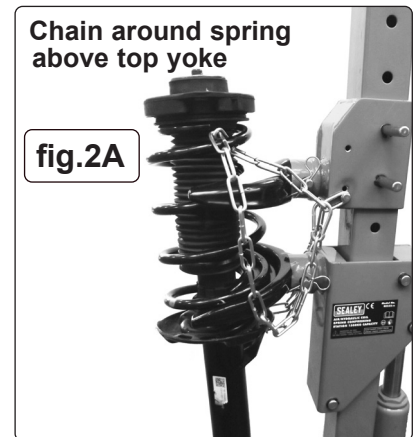
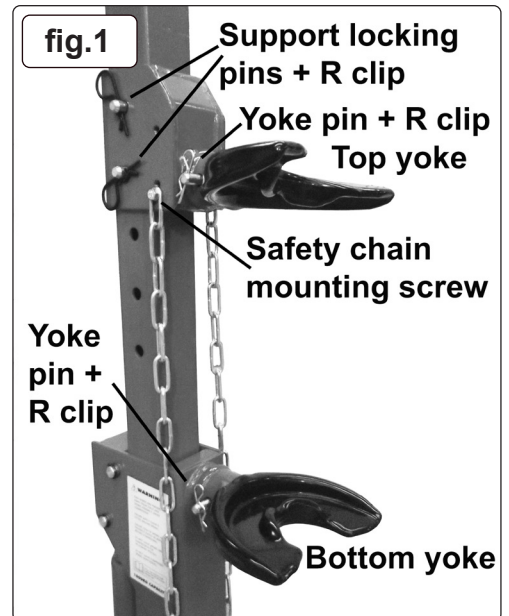

- 6.3.7. Remove complete strut carefully from the spring compressor.
- 6.3.8. When re-fitting the strut to the vehicle, the locking plate nut will need to be fully tightened using a torque wrench, to a setting in accordance with the vehicle manufacturer's specification.

7. MAINTENANCE

- 7.1. Before each use, check the spring compressor to ensure it is not damaged or worn. If in any doubt **DO NOT** use the spring compressor. Remove it from service immediately and contact your local Sealey stockist for advice and/or repairs.
- 7.2. Periodically clean the sliding columns and wipe over using a little transmission oil.
- 7.3. Any other maintenance required should be carried out by an authorised service agent.
- 7.4. If the spring compressor is not being used for a considerable length of time, disconnect the air supply and discharge any air in the cylinder by depressing the foot control lever. Drop a little Sealey air tool oil into the air inlet and cover to prevent the ingress of any foreign matter.



ENVIRONMENT PROTECTION

Recycle unwanted materials instead of disposing of them as waste. All tools, accessories and packaging should be sorted, taken to a recycling centre and disposed of in a manner which is compatible with the environment. When the product becomes completely unserviceable and requires disposal, drain any fluids (if applicable) into approved containers and dispose of the product and fluids according to local regulations.

Note: It is our policy to continually improve products and as such we reserve the right to alter data, specifications and component parts without prior notice.

Important: No Liability is accepted for incorrect use of this product.

Warranty: Guarantee is 12 months from purchase date, proof of which is required for any claim.

Sealey Group, Kempson Way, Suffolk Business Park, Bury St Edmunds, Suffolk. IP32 7AR



01284 757500



01284 703534



sales@sealey.co.uk



www.sealey.co.uk